

# TI TOWN TECHNOLOGY CO., LTD



Technology & innovation



# Technology & innovation

## TI TOWN TECHNOLOGY CO., LTD.

Ti Town Company was established in 1991. We focused on specializing and developing various chemicals industry pumps, filters and special alloys.

The concept of the company strives for upgrading the quality of pumps and developing new products.

Also, we own a number of product patents. "The goals of the company are to increase the industrial competitiveness and to create a win-win situation with the clients in the future".

We have been cooperating with a number of OEMs and we were successful.

### **Ti Town's main products :**

- Vertical cantilever seal-less pump
- Magnetically driven seal-less pump
- Thermoplastics/Stainless steel Cartridge & Bag filter
- Automatic stripper filter

All of the products are suitable for many kinds of metal surface treatments such as PCB/LCD wet processes, electroplating, electro less plating, waste water treatment and wet scrubber.

Ti Town also offers a complete line for the horizontal and vertical corrosion-resistant pumps in both high-strength thermoplastics and stainless steel. They are suited to a variety of metal finishing and electronics applications.

We sincerely invite you to join us.

Seek for an Agent or Distributors worldwide.

TI TOWN TECHNOLOGY CO., LTD.

NO.332, Sec. 2, Zhongyi Rd., Guishan Dist., Taoyuan City 33378, Taiwan

TEL : +886-3-318-2825 FAX : +886-3-318-2890

E-MAIL : [titown.pump@msa.hinet.net](mailto:titown.pump@msa.hinet.net)  
[service@titown.net](mailto:service@titown.net)

Web site : <http://www.titown.net>

# TME MAGNET SEALLESS CHEMICAL PUMPS[20W~7.5KW]

TME	20 (1)	180 (2)	V (3)	F (4)	R (5)	S (6)	1 (8)	XXX (9)	
TME	40 (1)	2 (2)	V (3)	F (4)	C (5)	F (6)	6 (7)	3 (8)	XXX (9)

## 1.Outlet dimension :

16 = 1/2"	50/55 = 2"
20 = 3/4"	65 = 2.5"
25 = 1"	
40 = 1.5"	

## 2. Drive motor :

20 = 20W	0 = 0.5HP
30 = 30W	1 = 1 HP
65 = 65W	2 = 2 HP
100 = 100W	3 = 3HP
180 = 180W	5 = 5HP
260 = 260W	7 = 7.5HP
400 = 400W	A = 10HP

## 3. Casing O-ring :

V = FKM (Viton)  
E = Epdm

## 4. Wet-end material :

F = GFRPP (20W~4.0KW)  
E = ETFE+CF (20W~4.0KW)  
P = CFRPP (0.37KW~7.5KW)

## 5. Impeller shaft/bearing :

C = Alumina ceramic / Carbon graphite  
R = Alumina ceramic / PTFE + CF  
A = Alumina ceramic / SIC  
B = SIC / Carbon graphite  
S = SIC/PTFE + CF  
K = SIC/SIC

## 6. Connection :

S = Screw (20W~3.7KW)  
H = Hose (20W~400W)  
F = Flang with oval holes (0.5HP~10HP)

## 7. Pump frequency :

5 = 50HZ  
6 = 60HZ  
None = common impeller size (20W~180W)

## 8. Motor voltages specific :

1 = 1Ø 110/220V  
2 = 1Ø 200/220V  
3 = 3Ø 220/380V  
4 = 3Ø 220/440V  
T = Special SPEC.

## 9. Reserve for Customization



## ■ The operating principle of TME magnetic drive pump

Introducing an additional magnetic field ensures permanent axial thrust compensation. If dry running occurs due to lack of liquid or for other reasons, the impeller assembly is automatically shifted by the additional magnetic field to a neutral position between the front and back casing. Heat generated by thrust friction can be reduced effectively. In this position there is negligible friction on the shaft when fitted with carbon graphite impeller bearing. Thereby preventing any thermal deformation and reducing wear.

**Wide gap between impeller bearing/rear thrust**  
When continuous operation

**Contact free operation**  
When dry running

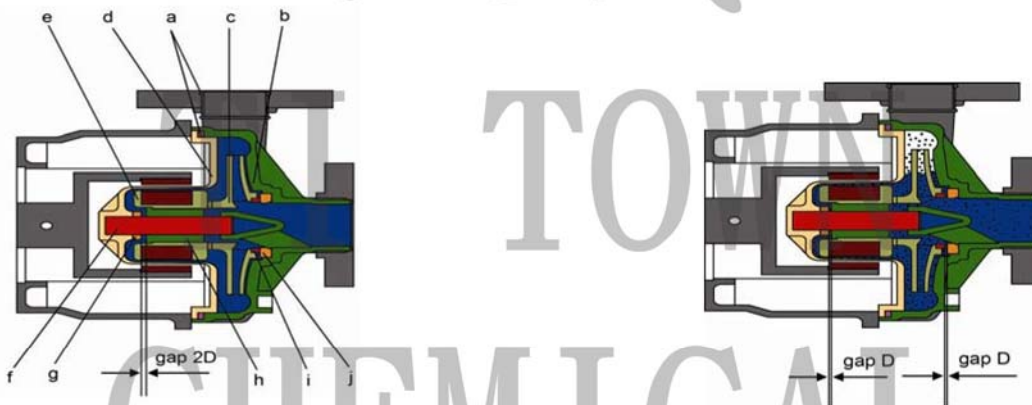

## ■ Section view and Wet-end materials

Model	VF(EF)	VP(EP)	VE(EE)
Mark	(20W~4.0KW)	(0.37KW~7.5KW)	(20W~4.0KW)
a. Casing O-ring	FKM (EPDM) ※		
b. Front casing	GFRPP	CFRPP	ETFE+CF
c. Impeller	GFRPP	CFRPP	ETFE+CF
d. Back casing	GFRPP	CFRPP	ETFE+CF
e. Magnet capsule	PP		ETFE
f. Shaft	High purity Alumina ceramic		High purity Alumina ceramic/S-SIC
g. Rear thrust	High purity Alumina ceramic		High purity Alumina ceramic/S-SIC
h. Impeller bearing	Carbon/PTFE+CF		Carbon/PTFE+CF/S-SIC
i. Mouth ring	PTFE+CF		
j. Trust ring	High purity Alumina ceramic		High purity Alumina ceramic/S-SIC

※AFLAS or FFKM are also available

**■ Specification (20W~400W × 50/60HZ , Determined with clear water at room temperature)**

TYPE	Curve		Drive MOTOR (w)	In/Outlet		MAX. Flow (L/min)		MAX. Head (M)	
	50HZ	60HZ		HOSE (mm)	Screw(G)	50HZ	60HZ	50HZ	60HZ
1620	a	A	20W/1Ø	Ø17	½"	20	24	2.2	3.0
1630	b	B	30W/1Ø	Ø17	½"	25	28	2.9	4.1
2030	c	C	30W/1Ø	Ø20	¾"	30	36	2.4	3.4
2065	d	D	65W/1Ø	Ø20	¾"	44	49	4.2	5.8
20100	e	E	100W/1Øor 3Ø	Ø20	¾"	60	68	5.0	6.9
25100	f	F	100W/1Øor 3Ø	Ø26	1"	75	85	4.6	6.6
20180	g	G	180W/1Øor 3Ø	Ø20	¾"	67	80	5.8	8.1
25180	h	H	180W/1Øor 3Ø	Ø26	1"	95	97	5.4	7.7
25260	i	I	260W/1Øor 3Ø	Ø26	1"	125	150	12.5	11.6
25400	j	J	400W/1Øor 3Ø	Ø26	1"	130	150	15.7	16.2

(Limit of SG1.1. Adjustable customization for specific gravity above 1.1)

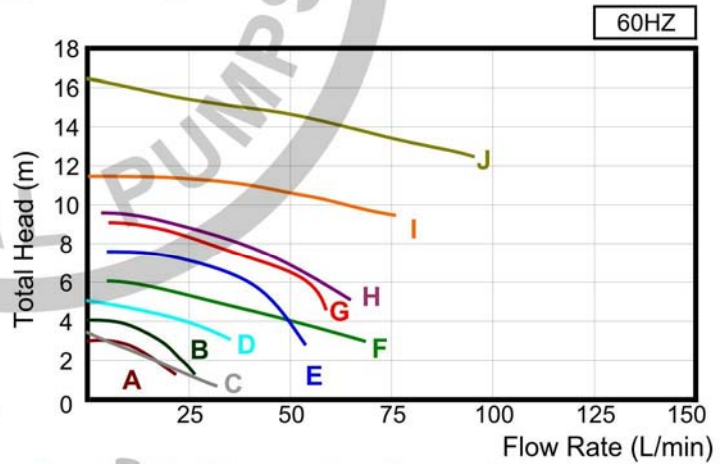
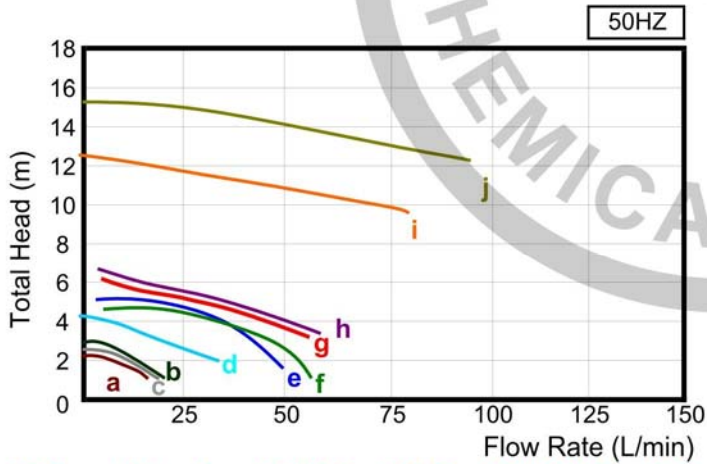

**■ Specification (0.5HP~10HP × 50/60HZ , Determined with clear water at room temperature)**

TYPE	Curve		Specific gravity	Drive motor HP(KW)	In/Outlet		MAX. Flow (L/min)		MAX. Head (M)	
	50HZ	60HZ			Flange	Screw(G)	50HZ	60HZ	50HZ	60HZ
250	k	K	1.1	0.5(0.37)	25 × 25	1"×1"	150	150	14.6	14.4
251	l	L	1.1	1.0(0.75)	25 × 25	1"×1"	150	150	20.9	21.4
400	m	M	1.1	0.5(0.37)	40 × 40	1.5"×1.5"	280	280	12	11.2
401	n	N	1.1	1.0(0.75)	40 × 40	1.5"×1.5"	340	360	18	17.4
402 【552】	o	O	1.1	2.0(1.5)	50 × 40 【50 × 50】	2"×1.5"	420	470	25	24.5
402H 【552H】	p	P	1.1	2.0(1.5)	50 × 40 【50 × 50】	2"×1.5"	150	150	29.4	32
403 【553】	q	Q	1.1	3.0(2.2)	50 × 40 【50 × 50】	2"×1.5"	550	600	29	29.4
403H 【553H】	r	R	1.1	3.0(2.2)	50 × 40 【50 × 50】	2"×1.5"	200	250	34.4	37.4
405 【555】	s	S	1.1	5.0(4.0)	50 × 40 【50 × 50】	2"×1.5"	600	615	37	40.7
505	t	T	1.1	5.0(4.0)	65 × 50	—	1000	1000	24	24.7
507	u	U	1.1	7.5(5.5)	65 × 50	—	1000	1000	30	32
50A	—	V	1.1	10(7.5)	65 × 50	—	—	1000	—	38
657	w	W	1.1	7.5(5.5)	80 × 65	—	1350	1300	27	27
65A	x	X	1.1	10(7.5)	80 × 65	—	1450	1400	33	32.5

(Limit of SG1.1. Adjustable customization for specific gravity above 1.1)

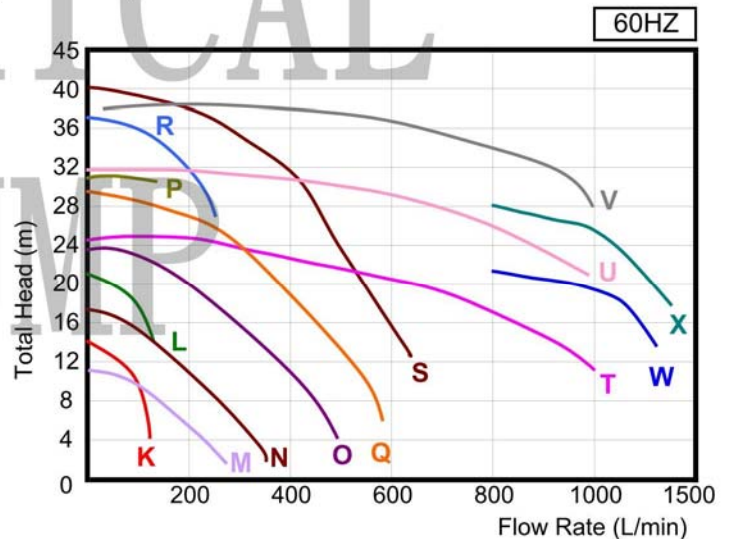
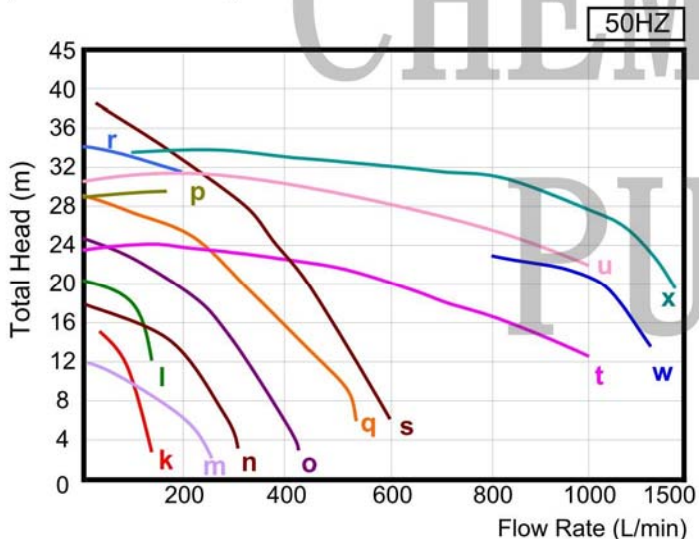

# TI TOWN CHEMICAL PUMP

ISO 2858 Magnetic drive with FCD 450 casing shell thermoplastic resin pump(5HP~25HP)

TMI — 32 B 150 E S S V 15 6 3 ××××  
 (1) (2) (3) (4) (5) (6) (7) (8) (9) (10) (11) (12)

- (1) Motor Mounted type :  
 None= IEC B5 motor  
 B = IEC B5 motor with base  
 P = bare shaft pump  
 (coupling drive type)  
 C = Coupling drive with IEC B3  
 foot mounted motor

- (5) Wet-end material :  
 E = cfr-Etfe

- (6) Impeller shaft :  
 S = Sic  
 C = Ceramic

- (2) Outlet dimension :  
 standard size ISO PN16  
 (JIS 10kg/cm<sup>2</sup> upon request)  
 32 = 50A×32A (JIS = 50A\*40A)  
 40 = 65A×40A  
 65 = 80A×65A

- (7) Impeller bearing :  
 S = Sic  
 G = carbon Graphite

- (8) Casing O-RING :  
 V = FKM (Viton)  
 E = Epdm  
 F = FFKM

- (10) Pump frequency :  
 5 = 50HZ  
 6 = 60HZ

- (3) Impeller range :  
 A = 3.7KW~7.5KW  
 B = 11KW~18.5KW

- ※(9) Drive motor :  
 5 = 5HP (3.7KW)  
 7 = 7.5HP (5.5KW)  
 10 = 10HP (7.5KW)  
 15 = 15HP (11KW)  
 20 = 20HP (15KW)  
 25 = 25HP (18.5KW)

- (11) Motor voltages specific :  
 3 = 3Ø 220/380V  
 4 = 3Ø 220/440V  
 T = special SPEC.

※ Recommend drive motor =  
 specific gravity \* Max. shaft power

- (4) Impeller size : (mm)

- (12) Reserve for customization



## ■ Features :

The TMI pump is a single-stage, magnetic driven back pull out system, centrifugal pump. TMIP series is full compliance with ISO 2858, means that this type pump is suitable for quick and simple system revamping. All wet-end parts are made by injection mold with various engineering plastic to provide superior corrosion resistance. TMI series exceptional mechanical provided by the ductile cast iron (FCD 450) pump casing cover and non metallic back casing cover, Maximum allowable pressure rating is 16 bar.

The magnets are in permanent magnets, ensuring coupling efficiency even when processing liquids with heavy specific gravity. Silicon carbide bearings allow the use of these pumps even with "difficult" and abrasive liquids. On the other hand, the low friction "Carbon graphite" version, together with our special design for magnetic unit balancing to provide superior cooling system, enables the pump to withstand short periods of dry running. 3.7kw~7.5kw pump shaft is supported between front casing and rear casing, 11kw~18.5kw pump shaft is supported by thermoplastic resin encapsulate FCD 450 bearing frame enables the pump to increased stability and withstand abnormal operation situation. The transmission is delivered through a magnetic drive shaft. coupling without any mechanical connection between impeller and This system ensures zero leakage, operator safety and elimination of dangerous odors or liquids to the atmosphere.

## ■ Application fields :

- |   |  |
|---|--|
| 1. Biochemistry                         | 6. Petrochemical industry                    |
| 2. Chemical and pharmaceutical industry | 7. Paper industry                            |
| 3. Chemical storage                     | 8. Textiles                                  |
| 4. Food industry                        | 9. Tanning industry                          |
| 5. Galvanizing                          | 10. Water and air treatment and purification |

## Wet-end materials

Materials	ECG	ESS
a O-ring	FKM / EPDM	
b Front casing	cfr-ETFE	
c Impeller		
d Back casing		
e Magnet capsule	ETFE	
f Shaft sleeve	Ceramic	SIC
g Rear trust		
h Impeller Bearing		
i Mouth ring		
j Trust ring	Carbon Graphite	
k Drain	Ceramic	
l Bearing frame		
m Impeller nut	cfr-ETFE	
n Magent nut	ETFE	

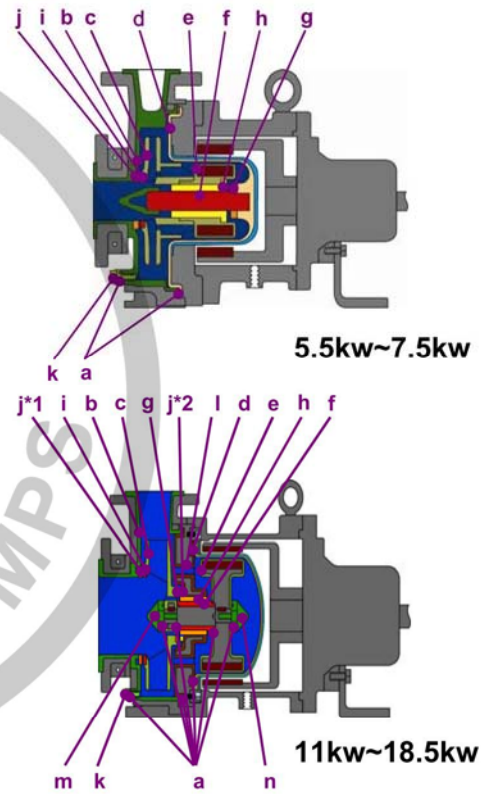

## Industrial-Process magnetic drive centrifugal pumps technical specifications

Technical specifications	50/60HZ
Wet-end Materials	CFR-ETFE
Flow rate	max 90 m <sup>3</sup> /h
Head	max 66 / 95 M
Electric motors	from 3.7 kw to 18,5kw
Temperature range	from 0°C to 90°C
Allowable pressure rating	max 16 bar
Viscosity	max 200 cps
SIC Allowable solids	Max. concentration 5% by weight,max. hardness 80(HS), particle size 50 μm

## Performance range chart

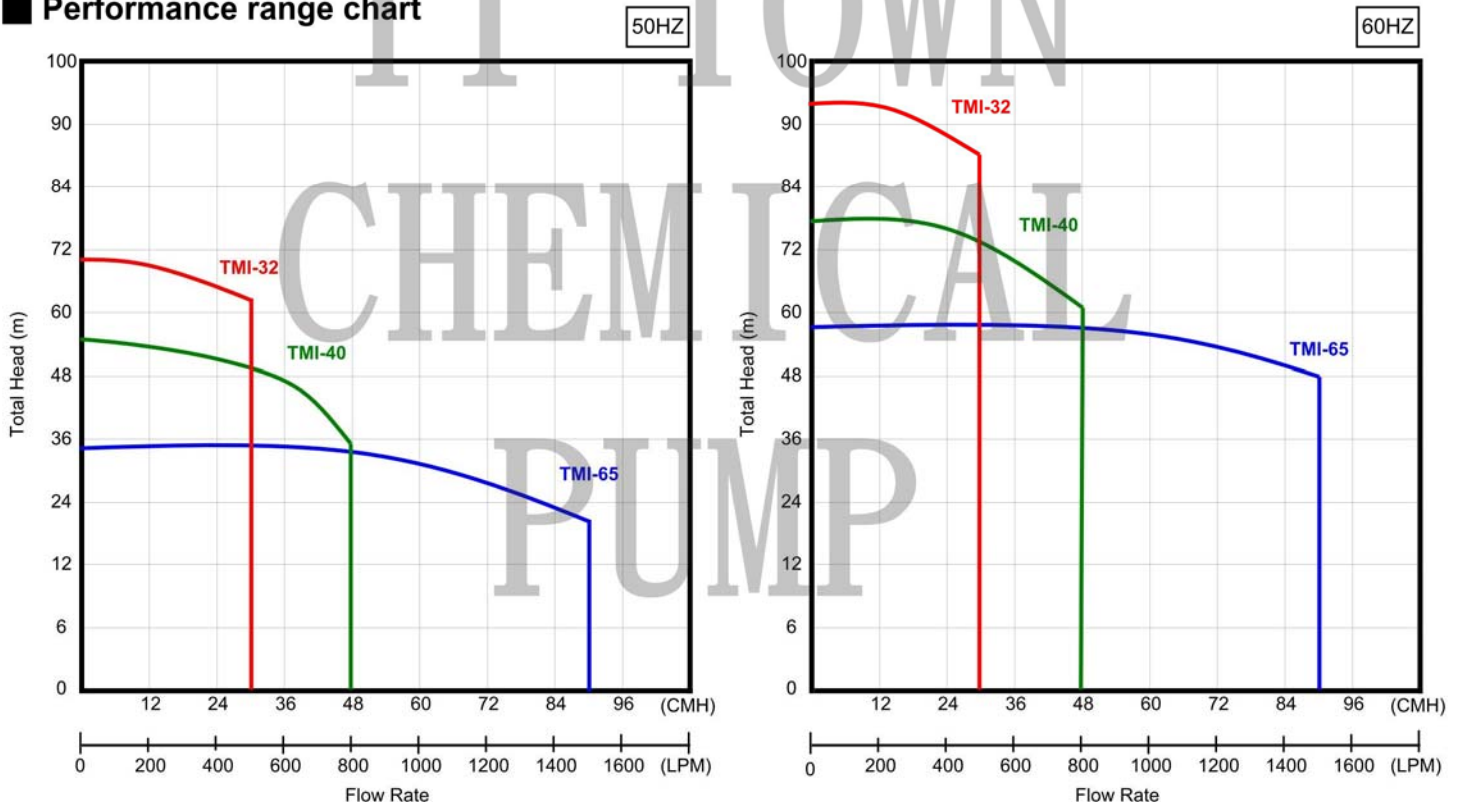

# TMI specification sheet

## ■ Specifications for 3.7KW~ 7.5KW

Model	In/ Outlet	Flow rate M3/ H	impeller size (mm)	50HZ		60HZ	
				Total head (M)	Max. Sp (kw)	Total head (M)	Max. Sp (kw)
TMI- 32A	50Ax32A	18	Ø120	—	—	23.1	3.4
			Ø130	—	—	28.6	4.4
			Ø140	22.9	3.4	34.7	5.3
			Ø150	26.8	4.1	41.1	6.4
			Ø160	31.0	4.7	48.2	7.7
			Ø170	35.4	5.4	54.2	8.3
			Ø180	39.9	6.1	—	—
TMI- 40A	65Ax40A	30	Ø130	—	—	22.1	3.7
			Ø140	—	—	28.5	4.8
			Ø150	21.6	3.4	34.4	6.0
			Ø160	26.0	4.5	42.0	7.8
			Ø170	30.5	5.4	48.5	9.4
TMI- 65A	80Ax65A	60	Ø180	35.6	6.3	—	—
			Ø120	—	—	14.1	4.2
			Ø130	—	—	21.0	5.9
			Ø140	17.0	4.6	29.0	8.1
			Ø150	21.6	5.9	—	—

## ■ Specifications for 11KW~ 18.5KW

Model	In/ Outlet	Flow rate M3/ H	impeller size (mm)	50HZ		60HZ	
				Total head (M)	Max. Sp (kw)	Total head (M)	Max. Sp (kw)
TMI- 32B	50Ax32A	18	Ø150	29.3	5.2	42.6	7.9
			Ø160	33.9	5.5	49.2	9.6
			Ø170	38.1	6.7	56.1	10.6
			Ø180	43.4	7.9	61.2	11.7
			Ø190	48.0	8.7	68.4	13.2
			Ø200	53.2	9.7	75.1	14.9
			Ø210	58.1	10.8	82.9	16.4
TMI- 40B	65Ax40A	30	Ø220	64.0	11.8	91.2	18.5
			Ø150	22.3	5.0	35.3	7.7
			Ø160	26.7	5.8	41.5	9.2
			Ø170	32.0	6.7	43.5	10.5
			Ø180	37.1	8.0	56.3	12.7
			Ø190	42.3	9.1	64.2	14.2
TMI- 65A	80Ax65A	60	Ø200	48.6	10.4	73.5	16.3
			Ø210	52.3	11.1	78.9	18.0
			Ø130	12.6	4.7	20.8	7.6
			Ø140	17.7	5.9	28.0	9.6
			Ø150	23.1	7.4	35.4	11.7
			Ø160	28.2	8.9	42.6	13.8
			Ø170	33.7	10.5	51.8	16.8
			Ø180	37.1	11.3	56.9	18.0

Test accordance with ISO 9906-2000 (clear water at room temperature)

Total Head = Suction Head + Delivery Head + Velocity Head

Max. Sp = Maximum drive Shaft Power at this impeller size



# TMS MAGNET SEALLESS CHEMICAL PUMPS

TMS —  $\frac{401}{(1)}$   $\frac{V}{(2)}$   $\frac{F}{(3)}$   $\frac{C}{(4)}$   $\frac{S}{(5)}$   $\frac{6}{(6)}$   $\frac{XXX}{(7)}$

## Introduction :



## Features :

1. Special sealless desing, high efficiency, complete liquid leakage free.
2. Mold by engineering plastic to increase mechanical strength. Superior corrosion resistance and long life.
3. Standard pump shaft/liner rings are 99.5% ceramic. Optional S-SIC are available for critical service applications.
4. Unique desing, simple assemble and easy maintenance.

## Application :

1. For circulation and transfer of chemical liquids plating filter
2. For circulation of chiller and sea-water
3. For chemical industries waste water
4. For circulation of aquarium water
5. Limit of specific gravity TMS: 1.2. Adjustable customization for specific gravity above 1.2

### (1) TYPE :

- 260 - 0.26KW
- 320 - 0.32KW
- 400 - 0.4KW
- 401 - 0.75KW
- 402 - 1.5KW
- 403 - 2.2KW
- 405 - 3.7KW

### (4) IMPELLER BEARING :

- C - CARBON GRAPHITE
- R - RULON

### (5) CONNECTION :

- S = SCREW
- H = HOSE
- F = FLANGE WITH OVAL HOLES

### (2) ORING :

- V - FKM (VITON)
- E - EPDM

### (6) PUMP FREQUENCY :

- 5 = 50HZ
- 6 = 60 HZ

### (3) MATERIAL (MAX °C) :

- F - GFRPP (80°C)
- P - CFRPP (80°C)
- K - PVDF (90°C)

### (7) RESERVE FOR CUSTOMIZATION

## SPECIFICATION (50/60Hz) :

Type	Connection In/Outlet HOSE (screw)	Voltage	Drive motor (KW)	Pole	Max. Flow (L/min)		Max. Head (M)		Weight (KG)
					50HZ	60HZ	50HZ	60HZ	
TMS-260	26mm(PF1")×26mm(PF1")	110/220V×1Ø or 220/380,440V×3Ø	0.26	2	120	125	12.2	12.2	9
TMS-320	26mm(PF1")×26mm(PF1")	110/220V×1Ø or 220/380,440V×3Ø	0.32	2	-	110	-	15	9
TMS-400	40A×40A	110/220V×1Ø or 220/380,440V×3Ø	0.40	2	280	300	12	12	14
TMS-401	40A×40A	220/380/440V×3Ø	0.75	2	330	360	16	16.8	19
TMS-402	50A×40A	220/380/440V×3Ø	1.50	2	425	470	22.9	21.2	38
TMS-403	50A×40A	220/380/440V×3Ø	2.20	2	545	575	26.2	26	40
TMS-405	50A×40A	220/380/440V×3Ø	3.70	2	500	615	28.2	38.8	50

## PERFORMANCE (50/60Hz) :

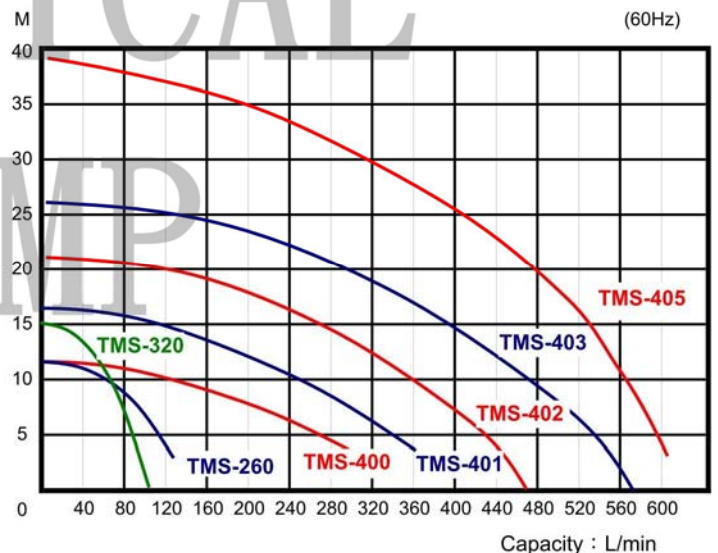
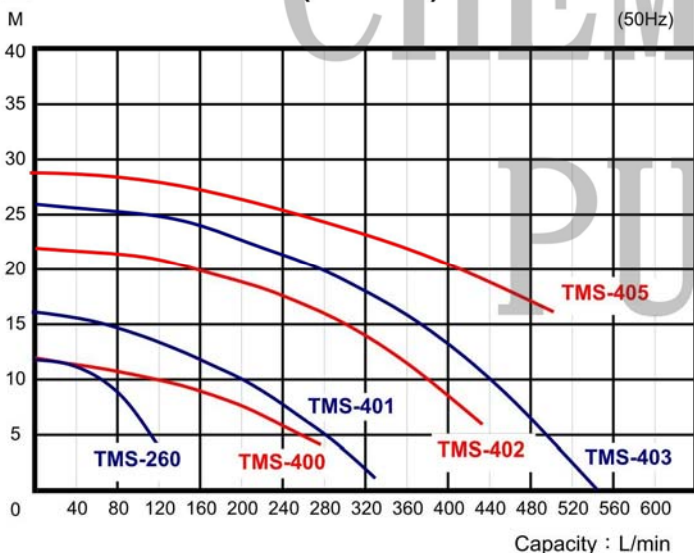



# DRY FREE VERTICAL CANTILEVER SEALLESS PUMPS

TDA	50	SP	5	6	V	F	—	XXX
(1)	(2)	(3)	(4)	(5)	(6)	(7)	(8)	(9)
Model	Outlet dimension	Specific gravity *1	Drive motor	Frequency	O-RING	Wet-end material	Connection type	Reserve for Customization
TD : FC BASE TDA : FC BASE TDB : PLASTIC BASE	40mm 50mm 65mm 80mm 100mm	SK : 1.1 SP : 1.4	1 : 1HP 2 : 2HP 3 : 3HP 5 : 5HP 7.5 : 7.5HP 10 : 10HP 15 : 15HP 20 : 20HP	5 : 50HZ 6 : 60HZ	V : FKM(Viton) E : EPDM	F : FRPP P : CFRPP C : CPVC K : PVDF	None : Flange S : Screw(BSP) A : ANSI Union PVC socket D : DIN Union PP socket J : JIS Union PVC socket U : CUSTOM-MADE Union	

## ■ Features :

- The pumps, made of highly chemical-resistant CFRPP, PVDF, CPVC and FRPP, are excellent for resisting heat and corrosion from chemical solutions.
- The impellers are specially designed to prevent air from getting into the pumps to ensure efficient work and high performance.
- The sealless design are no frictions when the pumps are working, so dry running or chemical liquid with particles will not cause malfunction of the pumps.
- All of the major components of our pumps are injection molded to ensure precise performance.
- The motors, which are protected by oil seals and vapor seal to resist corrosion from chemical vapors.

## ■ Specifications

Model	Curve		Specific gravity	HP	In/Outlet	Max.Flow (L/min)		Max.Head (M)		Weight TDA KG
	50HZ	60HZ				50HZ	60HZ	50HZ	60HZ	
40SK-1	a	A	1.1	1	50×40	280	240	12.6	11	34
40SK-2	b	B	1.1	2	50×40	350	350	16	17.7	43
40SK-3		C	1.1	3	50×40		400		23	45
50SK-3	d	D	1.1	3	65×50	400	500	20.5	21.2	46
50SK-5	e	E	1.1	5	65×50	730	700	26	29.2	64
65SK-5	f	F	1.1	5	80×65	800	850	22.5	25	64
50SK-7.5		G	1.1	7.5	65×50		790		37.5	94
65SK-7.5	h	H	1.1	7.5	80×65	1000	1050	25	31.8	95
65SK-10	i	I	1.1	10	80×65	1100	1100	28.5	35.4	100
80SK-15		J	1.1	15	80×80		1100		41.4	151
100SK-15	k	K	1.1	15	100×100	1370	1550	28	32	153
101SK-15	w	W	1.1	15	100×100	2000	1600	33	42	153
101SK-20	x	X	1.1	20	100×100	2200	2500	34	46	158
40SP-1	l	L	1.4	1	50×40	280	230	8.6	9.6	34
40SP-2	m	M	1.4	2	50×40	380	260	16	12.6	43
40SP-3		N	1.4	3	50×40		350		17.2	45
50SP-3	o	O	1.4	3	65×50	450	440	17	17.8	46
50SP-5	p	P	1.4	5	65×50	550	550	24.9	27	64
65SP-5	q	Q	1.4	5	80×65	700	550	21.5	25	64
50SP-7.5		R	1.4	7.5	65×50		500		34	94
65SP-7.5	s	S	1.4	7.5	80×65	940	850	23.9	26.6	95
65SP-10	t	T	1.4	10	80×65	1050	1050	26	31.8	100
80SP-15	u	U	1.4	15	80×80	1100	1150	28.5	38	151
100SP-15	v	V	1.4	15	100×100	1300	1350	26	31	153

## ■ PERFORMANCE CURVES (50HZ)

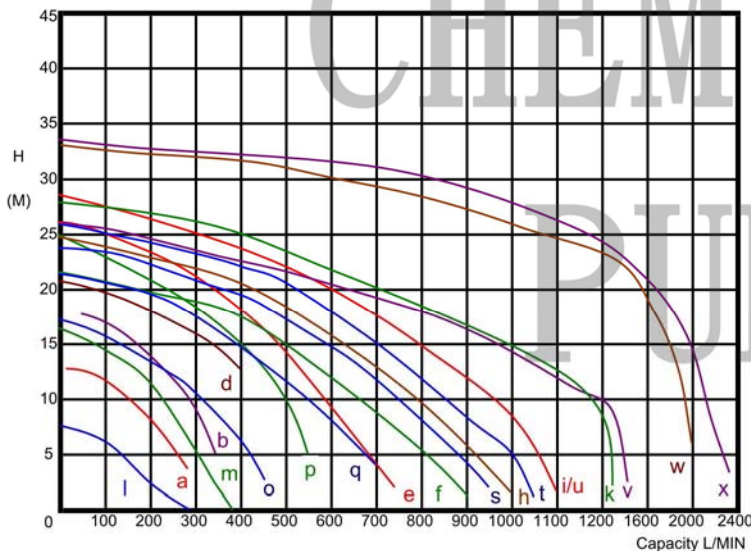

## ■ PERFORMANCE CURVES (60HZ)

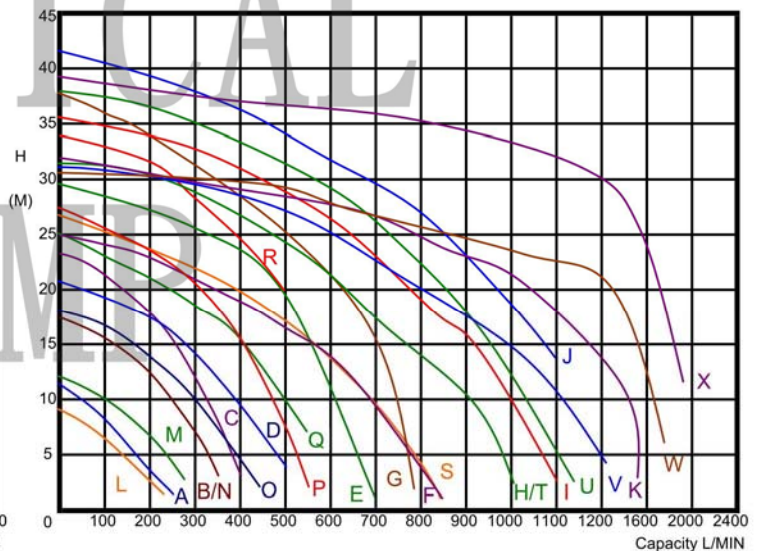

\* 1 : Adjustable customization specification for specific gravity above 1.4 .

## TDA/ TDB accessory's decomposition chart

● For 1~ 5 HP

● For 7.5~ 20 HP

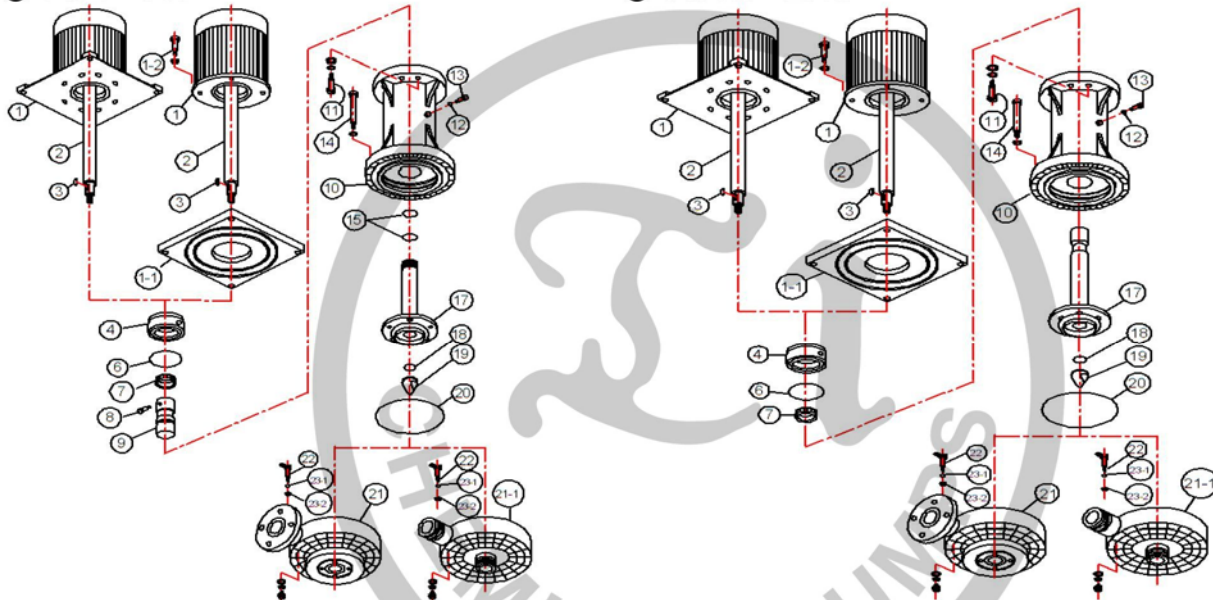

## TDA/ TDB DIMENSION (mm) / size watch

Model	HP	A	B	C *	D *	φ E	φ F	φ G	φ H	I	φ J *	φ K	φ L	φ M	N	O	P *	Q	R	S	T	U	V	W
40SK/ SP- one	1	350	425	742	317	50	120	155	230	4	177	40	105	145	4	170	164	186	65	222	260	222	260	15
40SK/ SP- 2	2	350	425	787	362	50	120	155	230	4	200	40	105	145	4	170	178	186	65	222	260	222	260	15
40SK/ SP- 3	3	350	425	787	362	50	120	155	230	4	200	40	105	145	4	170	178	186	65	222	260	222	260	15
50SK/ SP- 3	3	350	425	787	362	65	140	175	260	4	200	50	120	155	4	200	178	186	65	222	260	222	260	15
50SK/ SP- 5	5	350	425	836	411	65	140	175	260	4	238	50	120	155	4	200	202	186	65	222	260	222	260	15
50SK/ SP- 7.5	7.5	350	425	856	431	65	140	175	260	7	273	50	120	155	4	200	202	186	65	300	350	300	350	18
65SK/ SP- 5	5	350	425	836	411	76	150	190	260	8	238	65	140	175	4	200	202	186	65	222	260	222	260	15
65SK/ SP- 7.5	7.5	350	425	856	431	76	150	190	260	8	273	65	140	175	4	200	202	186	65	300	350	300	350	18
65SK/ SP- 10	10	350	425	886	461	76	150	190	260	8	273	65	140	175	4	200	202	186	65	300	350	300	350	18
80SK/ SP- 15	15	350	425	975	550	76	150	190	260	8	273	76	150	190	8	200	245	186	65	300	350	300	350	18
100SK/ SP- 15	15	350	425	975	550	100	175	210	260	8	273	100	175	210	8	200	245	186	65	300	350	300	350	18
101SK- 15	15	356	435	985	550	100	175	220	290	8	334	100	175	220	8	215	287	250	66	300	350	300	350	18
101SK- 20	20	356	435	985	550	100	175	220	290	8	334	100	175	220	8	215	287	250	66	300	350	300	350	18

\* : dimension will differ depending on the difference brand of the motor

## TDA/ TDB dimensional drawing ■ TDA/ TDB PARTS TABLE / part list

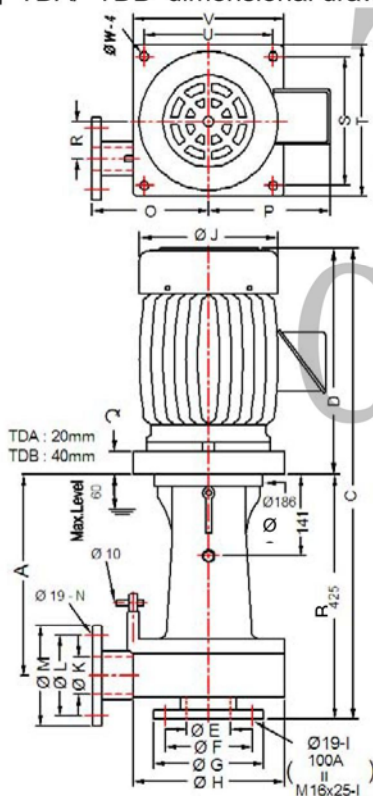

number	Accessory's name	integer	material quality	number	Accessory's name	integer	material quality
1	LONG SHAFT MOTOR	1	FC	12	O- RING	1	FKM, EPDM
1-1	MOUNTING	1	TDA: FC TDB: PLASTIC	13	BOLT	1	HTPVC
1-2	BOLT	4	SUS	14	BOLT NUT	8	SUS, Ti, PPS
2	SHAFT	1	SUS	15	O- RING	2	FKM, EPDM
3	KEY	1	SUS	17	IMPELLER	1	CFRPP, PVDF, FRPP, CPVC
4	SEAL CASE	1	FRPP/ CERAMIC	18	O- RING	1	FKM, EPDM
6	O- RING	1	FKM, EPDM	19	IMPELLER NUT	1	CFRPP, PVDF, FRPP, CPVC
7	VAPOR SEAL	1	FKM, EPDM	20	O- RING	1	FKM, EPDM
8	BOLT	1	SUS, Ti	21	PUMP CASING	1	CFRPP, PVDF, FRPP, CPVC
9	SEAL HOLDER	1	FRPP	◎22	AIR VALVE	1	CFRPP, PVDF, FRPP, CPVC
10	PUMP COLUMN	1	CFRPP, PVDF, FRPP, CPVC	◎23-1	O- RING	1	FKM, EPDM
11	BOLT	8	SUS, Ti	◎23-2	VALVE PACKING	1	FKM, EPDM

★ Our company hold design change zhi power no longer separately announcement

◎ : Optinal parts

# TFV/TFO/TFP/TFQ DRY FREE INTANK VERTICAL CANTILEVER SEALLESS PUMPS

<b>TFV</b>	$\frac{1}{8}$	<b>V</b>	<b>P</b>	<b>T</b>	<b>1</b>				
(1)	(5)	(8)	(9)	(11)*1	(13)				
<b>TFP</b>	$\frac{1}{8}$	<b>V</b>	<b>P</b>	<b>A</b>	<b>T</b>	<b>1</b>			
(2)	(5)	(8)	(9)	(10)	(11)*1	(13)			
<b>TFV</b>	<b>40</b>	<b>SK</b>	<b>5</b>	<b>6</b>	<b>V</b>	<b>P</b>	<b>T</b>	<b>3</b>	
(1)	(3)	(4)	(6)	(7)	(8)	(9)	(12)*2	(13)	
<b>TFP</b>	<b>40</b>	<b>SK</b>	<b>5</b>	<b>6</b>	<b>V</b>	<b>P</b>	<b>A</b>	<b>T</b>	<b>4</b>
(2)	(3)	(4)	(6)	(7)	(8)	(9)	(10)	(12)*2	(13)

TFV series



TFO series TFP series



TFQ series



(1) Model TFV : In-tank Vertical pump with quadrilateral interface  
TFO : In-tank Vertical pump with round interface

(2) Model TFP/TFQ : In-tank Vertical pump with P.P. mounting plate

(3) Outlet dimension : 40 mm

(4) Specific Gravity : SK=1.1 , SP=1.4

(5) Motor power :  $\frac{1}{15}$ HP ,  $\frac{1}{8}$ HP ,  $\frac{1}{4}$ HP ,  $\frac{1}{2}$ HP , 1HP

(6) Motor power :

0 = 0.75HP    1 = 1HP    2 = 2HP    3 = 3HP  
5 = 5HP    7.5 = 7.5HP    10 = 10HP

(7) Frequency : 5=50HZ , 6=60HZ

(8) Casing Oring : V = FKM(Viton) , E = EPDM

(9) Wet-end material : P = CFR-PP , F = FR-PP , K = PVDF

(10) Union socket(only for TFP/TFQ series) :

A = ANSI PVC socket , D = DIN PP socket  
J = JIS PVC socket

(11) Shaft sleeve :

(\* 1 : Optional parts only available for  $\frac{1}{15}$  HP to  $\frac{1}{2}$  HP)

None = Standard type

T = With Titanium shaft sleeve

(12) Clamp material :

(\* 2 : Optional parts only available for 5HP , 7.5HP & 10HP)

None = Standard type ( below 3HP )

S = SUS316

T = Titanium

(13) Motor Voltages Specific :

1 = 1Ø 110/220V , 3 = 3Ø 220/380V

4 = 3Ø 220/440V , T = special SPEC.

## Features :

- The pumps, made of highly chemical-resistant CFRPP, PVDF and FRPP are excellent for resisting heat and corrosion from chemical solutions.
- The motors, which are protected by oil seals and vapor seal to resist corrosion from chemical vapors.

## TFV/TFP SPECIFICATION

Model	Curve		Specific gravity	HP	In/Outlet	Max.Flow (L/min)		Max.Head (M)		Weight ( KG )
	50HZ	60HZ				50HZ	60HZ	50HZ	60HZ	
TFV/TFP 1/15	a	A	1.3	1/15	20×16	40	50	2.2	3.5	4.8
TFV/TFP $\frac{1}{8}$	b	B	1.3	$\frac{1}{8}$	25×20	54	68	2.9	4.6	5
TFV/TFP $\frac{1}{4}$	c	C	1.3	$\frac{1}{4}$	25×20	90	106	5	7.4	8
TFV/TFP $\frac{1}{2}$	d	D	1.3	$\frac{1}{2}$	25×25	100	120	6.4	9.6	8.2
TFV/TFP $\frac{1}{2}$	e	E	1.3	$\frac{1}{2}$	25×25	110	130	7.9	11.5	8.3
TFV/TFP 25SK-0	f	F	1.1	$\frac{3}{4}$	40×25	200	200	9.2	11	19
TFV/TFP 40SK-1	g	G	1.1	1	50×40	250	300	12.8	12.2	20
TFV/TFP40SK-2	h	H	1.1	2	50×40	310	360	13	18.5	24
TFV/TFO/TFP 40SKH-2	h1	H1	1.1	2	50×40	370	395	18.2	17.8	38
TFV/TFO/TFP 40SK-3	i	I	1.1	3	50×40	400	430	21	25.8	40
TFV/TFO/TFP 40SKH-3	i1		1.1	3	50×40	435		25		40.5
TFV/TFO/TFP 40SK-5	j	J	1.1	5	50×40	550	570	30	31.5	50
TFV/TFO/TFP 40SK-7.5	k	K	1.1	7.5	50×40	600	650	33	42	61
TFV/TFO/TFP40SK-10	l	L	1.1	10	50×40	650	720	37	49	67
TFV/TFP 25SP-0	m	M	1.4	$\frac{3}{4}$	40×25	190	180	7.2	8	19
TFV/TFP 40SP-1	n	N	1.4	1	50×40	290	230	11.1	11	20
TFV/TFP 40SP-2	o	O	1.4	2	50×40	310	340	12.8	16	24
TFV/TFO/TFP 40-SPH-2	o1		1.4	2	50×40	350		15.1		38
TFV/TFO/TFP 40SP-3	p	P	1.4	3	50×40	400	380	19.5	19	40
TFV/TFO/TFP 40SPH-3	p1		1.4	3	50×40	400		20.5		40.5
TFV/TFO/TFP 40SP-5	q	Q	1.4	5	50×40	500	500	25	28.8	50
TFV/TFO/TFP 40SP-7.5	r	R	1.4	7.5	50×40	550	550	30	32	61
TFV/TFO/TFP 40SP-10	s	S	1.4	10	50×40	600	650	30	41.2	67

## PERFORMANCE CURVES (50Hz)

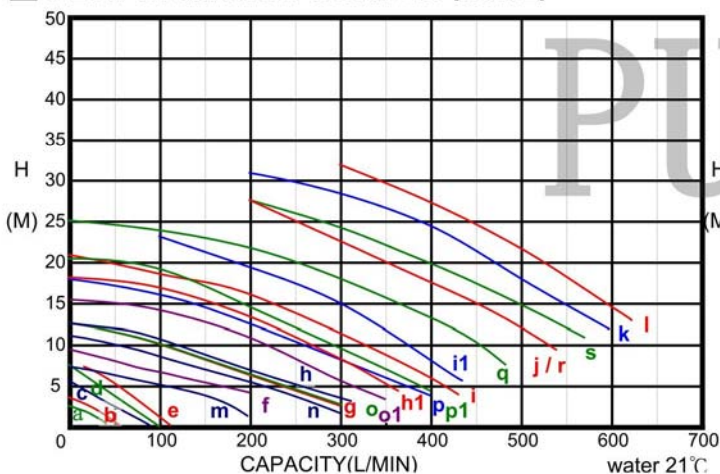

## PERFORMANCE CURVES (60Hz)

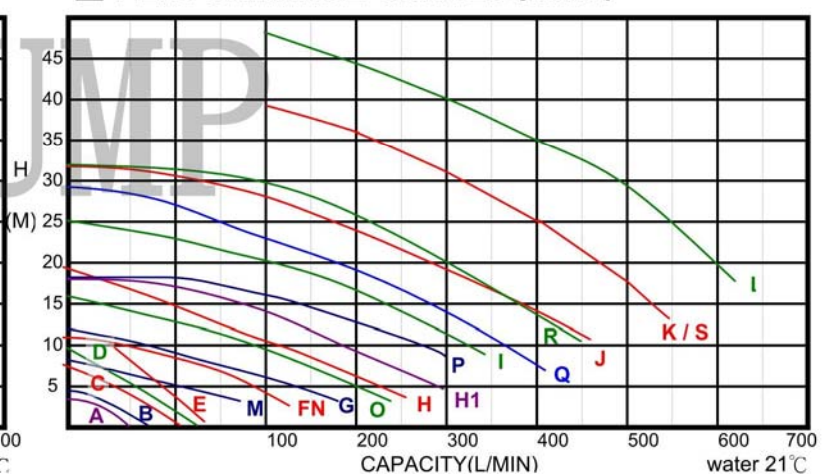

## ■ Exploded view and parts list

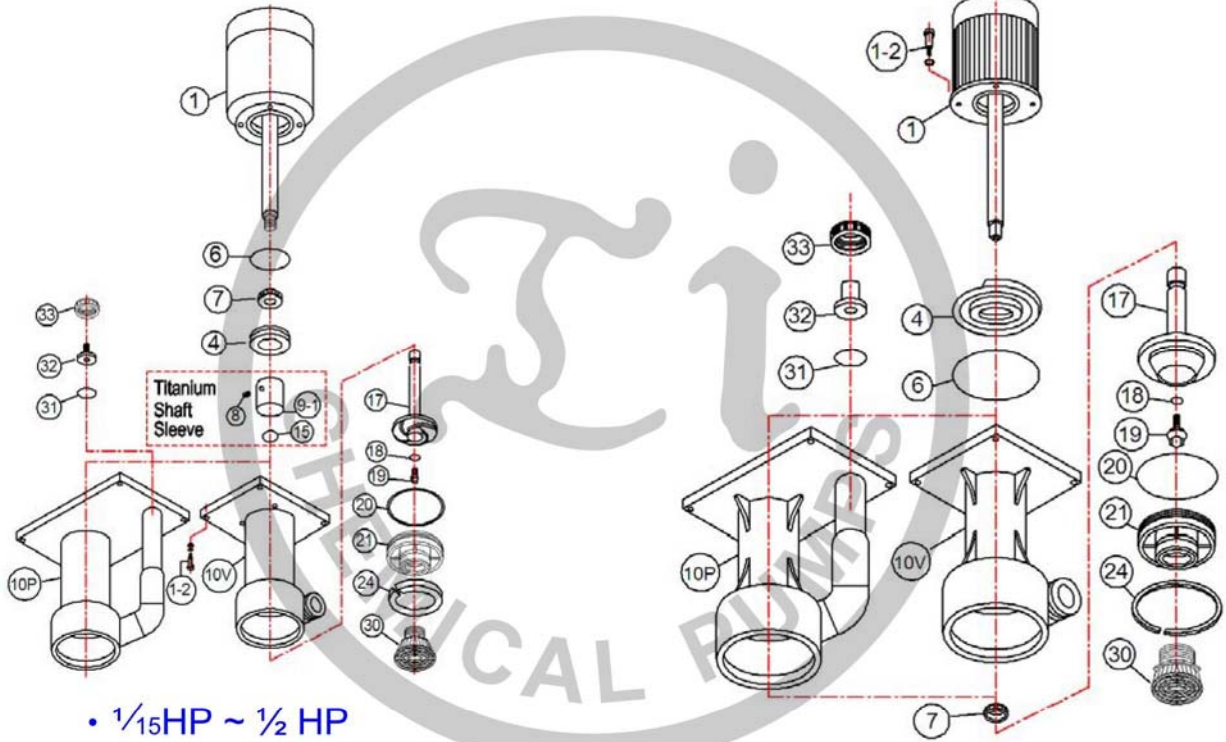

• 1/15HP ~ 1/2 HP

PN	Parts name	material
1	Motor with Long Shaft	Fc+AL+SUS
1-2	Bolts	SUS
3	Key	SUS
4	Seal Case	PP+ceramic
6	Seal Case O-ring	FKM / EPDM
7	Vapor Seal	FKM
8	Bolts	SUS
9	Seal Holder	PP
* 9-1	Seal Holder	Titanium
10 V	TFV Pump Column	FRPP / CFRPP / PVDF
10 O	TFO Pump Column	FRPP / CFRPP / PVDF
10 P	TFP Pump Column	FRPP / CFRPP / PVDF
15	Impeller Sleeve O-ring	FKM / EPDM
17	Impeller	FRPP / CFRPP / PVDF
18	Impeller Nut O-ring	FKM / EPDM
19	Impeller Nut	FRPP / CFRPP / PVDF
20	Casing O-ring	FKM / EPDM
21	Pump Casing	FRPP / CFRPP / PVDF
24	C-clip	FRPP / CFRPP / PVDF
25	Gap Spacer	FRPP / CFRPP / PVDF
26	Bolt	CPVC / PVDF
★ 27	Clamp	SUS / Titanium
★ 28	Bolt	SUS / Titanium
★ 29	Nuts	SUS / Titanium
◎ 30	Inlet Strainer	PP
31	Union O-ring	FKM / EPDM
32	Union Connector	PP / PVC / PVDF
33	Union Nut	FRPP

• 3/4 HP ~ 2 HP

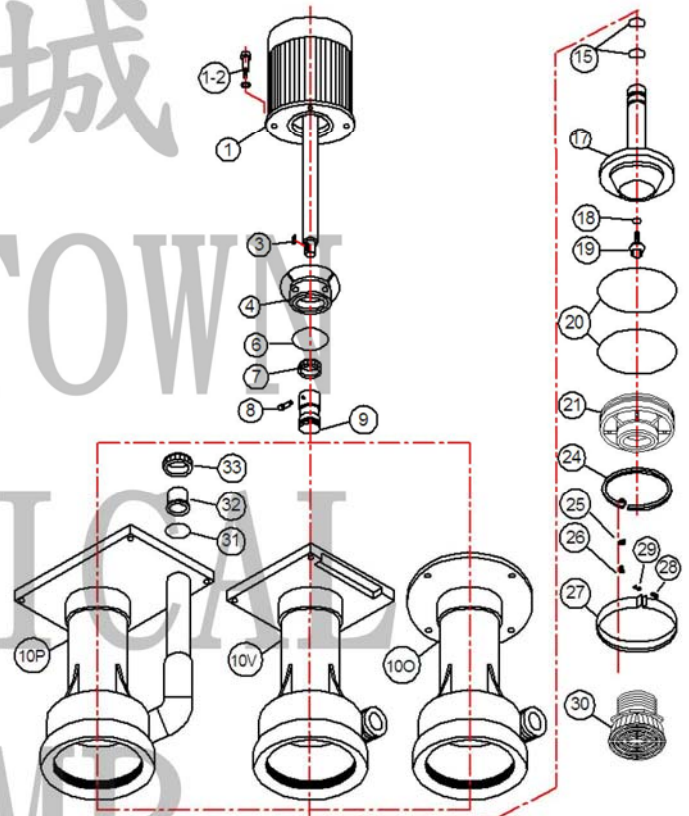

• 3 HP ~ 10 HP

\* Optional parts. Only available for Titanium Shaft Sleeve. ( available for 1/15 HP to 1/2 HP )

★ Optional parts. Only available for 5HP、7.5HP & 10HP

◎ Optional parts ( available for 3/4"、1"、1 1/2"、2" MPT )

# TB Quick Open Interlock Filter

**TB F U – 40 E S P J S 50**  
**(1) (2) (3) (4) (5) (6) (7) (8) (9) (10)**

- (1) Filtration type :  
 TB = Filter bag with metal strainer holder  
 TBT = 10" Tamis bag with PP strainer holder
- (2) Body material : F = FRPP  
 P = CFRPP
- (3) Inlet direction :  
 None = Inlet in the BOTTOM of the Barrel  
 U = Inlet in the SIDE of the Barrel  
 (only for TB-U type)
- (4) Union size : 40mm
- (5) Oring material : E = EPDM  
 V = FKM ( Viton )
- (6) Strainer.shaft&bolts material : S = SUS  
 T = TITANIUM
- (7) Union socket : P = PP  
 V = PVC
- (8) Union SPEC (socket) :  
 J = JIS  
 A = ANSI  
 D = DIN
- (9) Security switch :  
 None = WITHOUT proximity switch  
 S = WITH proximity switch
- (10) Filter fineness :  
 (P.P. Needle felt)  
 0.5~200  $\mu$ m



## Applications :

- ① PCB/LCD wet processing
- ② Chemical or water recirculation
- ③ Plating solutions recirculation

## Features :

- ① Filter housing is a ONE-PIECE injected molding that can resist high temperature and pressure.
- ② Mould parts easy to assemble without welding.
- ③ All of the filter element can be take out. Easy to maintain, Ensure barrier-free cleaning and doesn't pollute the outlet pipeline system.
- ④ Various filtration methods are available (TB/TB-U/TBT)
- ⑤ Special filter element design with low hydraulic friction loss.
- ⑥ Optional lid proximity switch to increase safety.

Example :

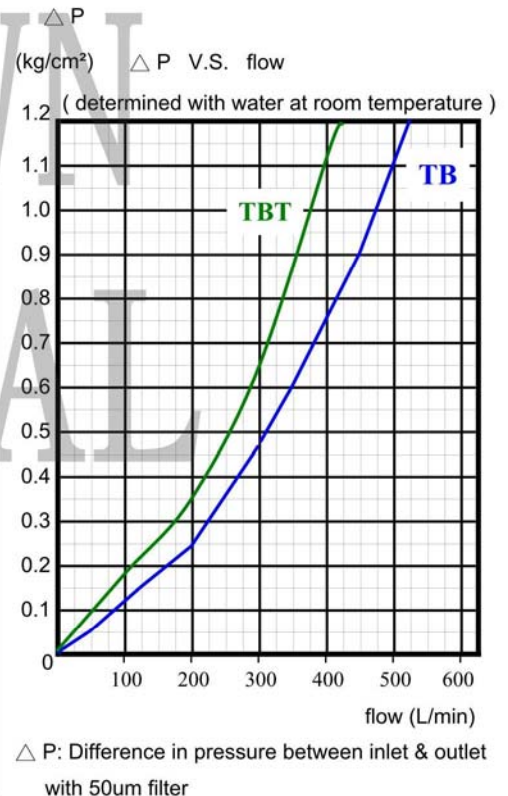
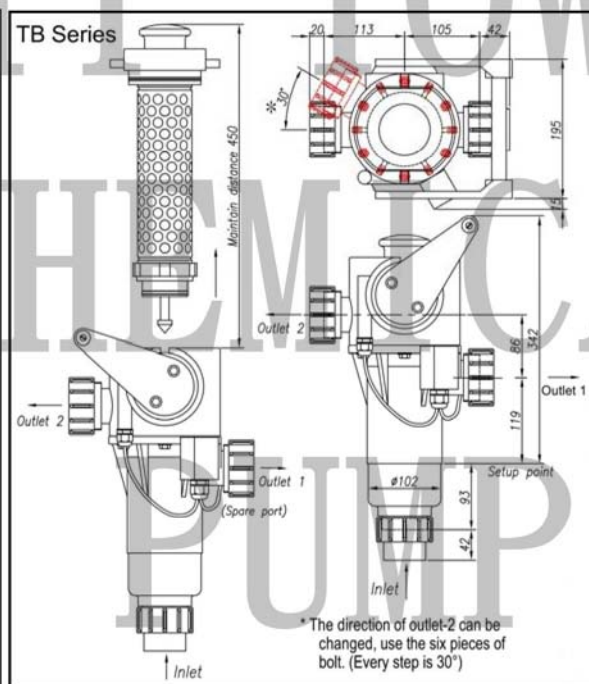
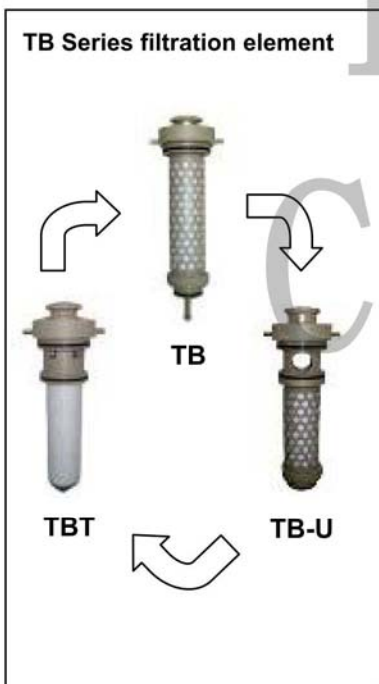

# BF Quick Open Interlock Bag Filter Housing

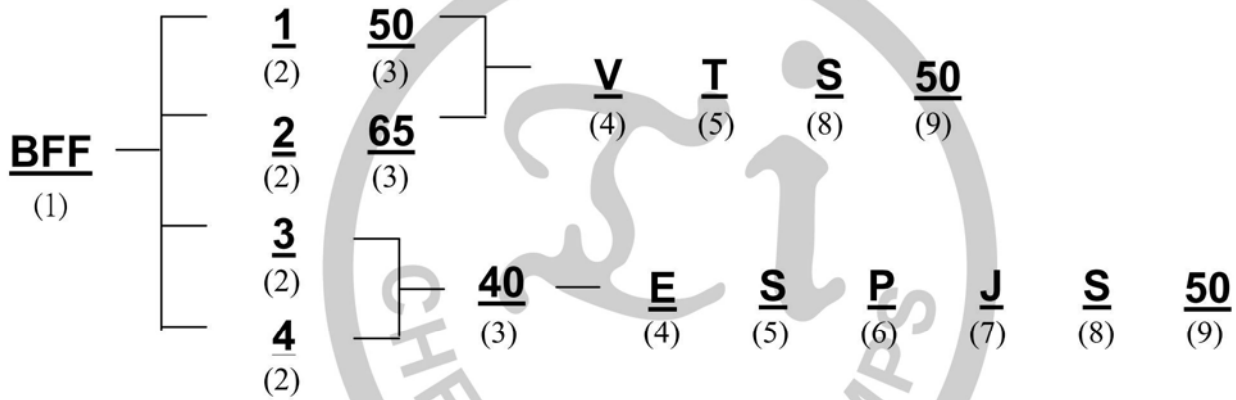

(1) Model: BFF (FRPP Bag Filter housing)

(2) Filter Bag SPEC :

- No.3(φ 4"\*9"L)
- No.4(φ 4"\*15"L)
- No.1(φ 7"\*16"L)
- No.2(φ 7"\*32"L)

(3) In/Outlet size :

- 40 : 1.5" Union
- 50 : 50A Flange(with oval holes can fit JIS 10K,ISO PN16,ANSI 150P)
- 60 : 65A Flange(with oval holes can fit JIS 10K,ISO PN16,ANSI 150P)

(4) Oring material:

- E : EPDM
- V : FKM(Viton)

(5) Shaft&Bolts:

- S : SUS304
- T : Titanium

(6) 1.5" Union socket :

- P : PP
- V : PVC

(7) 1.5" Union SPEC:

- J : Jis
- A : Ansi
- D : Din

(8) Security switch :

- None = WITHOUT switch
- S = WITH proximity switch

(9) Filter fineness :

- available 0.5~200μm



BFF Filter specification :

Model	In/Out	Bag specification	Weight	Volume
3	40	φ 4"*9"L	4.5Kg	1.4L
4	40	φ 4"*15"L	4.7Kg	3.8L
1	50	φ 7"*16"L	17.5Kg	16L
2	65	φ 7"*32"L	19.5Kg	22L

BF Bag filter housing can be used with standard filter bags to filter impurities, or with coarse filter woven mesh as a self-priming basket strainer at the pump inlet. Very compact, little space requirement and low pressure loss. The bag pressing is standard equipment, which can force the filter bag to be positioned in the seat smooth. The filter element can be easily replaced without using special tools. Short process interruption and minimal set-up times in case of maintenance work. The sealing structure adopts a double sealing surface X-ring structure. The X-ring is embedded between the cover and the barrel. The more operating pressure, the better X-ring tightness. No need to set the nut locking torque value to achieve the leak-proof. Since the handle has angle limit points for opening and closing the cover, two security switches can be optional purchased to improve work safety.

# CU Quick Open Interlock Cartridge Filter Housing

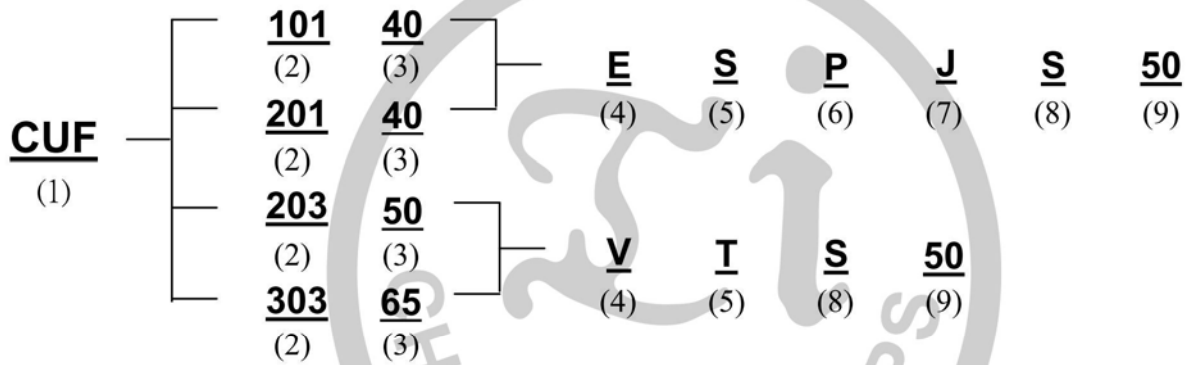

(1) Model: CU (FRPP Cartridge filter that outlet in the Upper of the housing)

(2) Cartridge SPEC:

- 101 : 10"\*1PC
- 201 : 20"\*1PC
- 203 : 20"\*3PCS
- 303 : 30"\*3PCS

(3) In/Outlet size :

- 40 : 1.5" Union
- 50 : 50A Flange (with oval holes can fit JIS 10K, ISO PN16, ANSI 150P)
- 60 : 65A Flange (with oval holes can fit JIS 10K, ISO PN16, ANSI 150P)

(4) Oring material:

- E : EPDM
- V : FKM (Viton)

(5) Shaft & Bolts:

- S : SUS304
- T : Titanium

(6) 1.5" Union socket :

- P : PP
- V : PVC

(7) 1.5" Union SPEC:

- J : Jis
- A : Ansi
- D : Din

(8) Security switch :

- None = WITHOUT switch
- S = WITH proximity switch

(9) Filter fineness :

available 0.5~200µm



CU Filter specification :

Model	In/Out	cartridge type	Weight
101	40	10"*1 PC	4.2Kg
201	40	20"*1 PC	4.4Kg
203	50	20"*3 PCS	17.7Kg
303	65	30"*3 PCS	19.7Kg

CU Cartridge filter that outlet in the Upper of the housing can be used with a DOE filter (OD<Ø65mm/ID> Ø28mm). Because the filter barrel combination method adopts a bottom-in-top-out type, the filter holder can be completely taken out, maintenance and cleaning are trouble-free, and it does not pollute the clean side pipeline. Reasonable In-Line piping configuration can reduce piping elbows and ensure that no air accumulates inside the filter barrel. Very compact, little space requirement and low pressure loss. The sealing structure adopts a double sealing surface X-ring structure. The X-ring is embedded between the cover and the barrel. The more operating pressure, the better X-ring tightness. No need to set the nut locking torque value to achieve the leak-proof. Since the handle has angle limit points for opening and closing the cover, two security switches can be optional purchased to improve work safety.

# CB Quick Open Interlock Cartridge Filter Housing

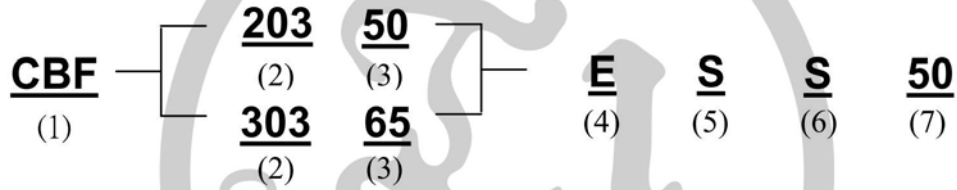

(1) Model: CB (FRPP Cartridge filter that outlet in the Bottom of the housing)

(2) Cartridge SPEC:

203 : 20"\*3PCS  
303 : 30"\*3PCS

(3) In/Outlet size :

50 : 50A Flange (with oval holes can fit JIS 10K, ISO PN16, ANSI 150P)  
60 : 65A Flange (with oval holes can fit JIS 10K, ISO PN16, ANSI 150P)

(4) Oring material:

E : EPDM  
V : FKM (Viton)

(5) Shaft & Bolts:

S : SUS304  
T : Titanium

(6) Security switch :

None = WITHOUT switch  
S = WITH proximity switch

(7) Filter fineness :

available 0.5~200µm

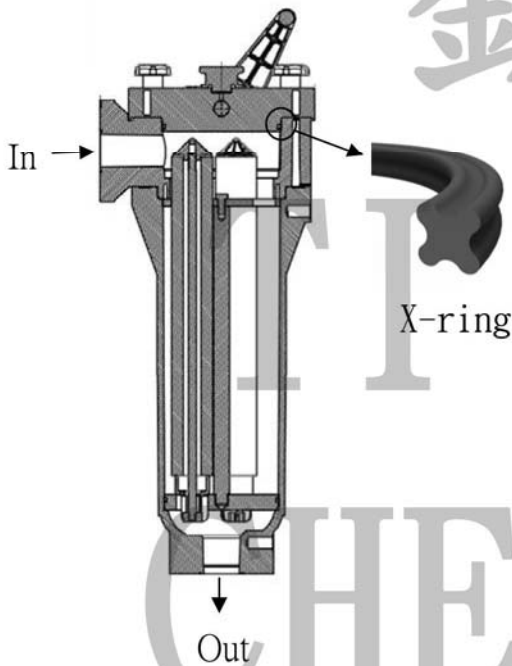

CB Filter specification :

Model	In/Out	cartridge type	Weight
203	50	20"*3 PCS	18.4Kg
303	65	30"*3 PCS	20.4Kg

CB Cartridge filter that outlet in the Bottom of the housing can be used with DOE filter (OD<Ø65mm/ID> Ø28mm). The filter central rod and filter seat are unique designed to reduce pressure loss. Very compact and little space requirement. The sealing structure adopts a double sealing surface X-ring structure. The X-ring is embedded between the cover and the barrel. The more operating pressure, the better X-ring tightness. No need to set the nut locking torque value to achieve the leak-proof. Since the handle has angle limit points for opening and closing the cover, two security switches can be optional purchased to improve work safety.



## Filter Housing for P.C.B. Etching machine

PP	—	20	07	E	T	50A	XXXX
(1)		(2)	(3)	(4)	(5)	(6)	(7)
PPU	—	20	06	V	T	50A	XXXX
(1)		(2)	(3)	(4)	(5)	(6)	(7)
TI	—	30	07	V	65A	XXXX	
(1)		(2)	(3)	(4)	(6)	(7)	
TGF	—	30	12	E	T	65A	XXXX
(1)		(2)	(3)	(4)	(5)	(6)	(7)

(1) Model

PP : LOWER hydraulic pressure losses PP filter housing

PPU : Outlet in the upper of the Barrel & LOWER hydraulic pressure losses PP filter housing

TI : LOWER hydraulic pressure losses Titanium filter housing

TGF : P.P. filter housing

(2) Cartridge length : 10=10"

20=20"

30=30"

(3) Number of cartridges

(4) Elastomer of barrel : E=EPDM

V=FKM (Viton)

(5) Clamp and bolts material : S=SUS

T=Titanium

(6) Bore size : Flange JIS 10KG/cm<sup>2</sup>

(7) Reserve for customization



TI Series

PP/TGF Series

PPU Series

Model	No of cartridges	Max pressure (kg/cm <sup>2</sup> )	Barrel Dimension (mm)
PP-1007/2007/3007	7	4kg/cm <sup>2</sup>	Ø 250
PPU-1006/2006/3006	6	3.5kg/cm <sup>2</sup>	Ø 315
TI-1007/2007/3007	7	5kg/cm <sup>2</sup> (PP cover) 8kg/cm <sup>2</sup> (Titanium cover)※	Ø 216
TGF-1007/2007/3007	7	4kg/cm <sup>2</sup>	Ø 250
TGF-1012/2012/3012	12	3.5kg/cm <sup>2</sup>	Ø 315

※Option specification

# TFM-100 Automatic stripper filter

## TFM Specification

TFM — 100 A 32  
(1) (2) (3) (4)

1. TFM : Automatic stripper filter made by stainless steel.
2. Connect flange : 100A ( 4" ) JIS 10kg/cm<sup>2</sup>
3. Strainer accuracy : A = Ø 0.3mm punching sheet  
B = Ø 0.7mm punching sheet  
C=Custom made slot sieve(available 0.02~0.3mm)
4. Motor Voltages Specific :  
11 = 1Ø 110V 、 32 = 3Ø 220V 、 34 = 3Ø 440V  
12 = 1Ø 220V 、 33 = 3Ø 380V 、 T = special SPEC.

All wet-end components are **SCS13 / SUS304**

## General specific :

- Operating pressure : 5kg/cm<sup>2</sup> ( MAX )
- Max capacity : 1500LPM
- Consumption power : 100W gear motor
- Weight : 140kg

## Features

- All wet-end parts are SCS13 or SUS304
- Special design with shaft seal to protect rotary parts and bearings in good conditions even leakage occurs
- Automatic carry stripper away without air purge
- All revolving parts are hidden for safety

## Introduction

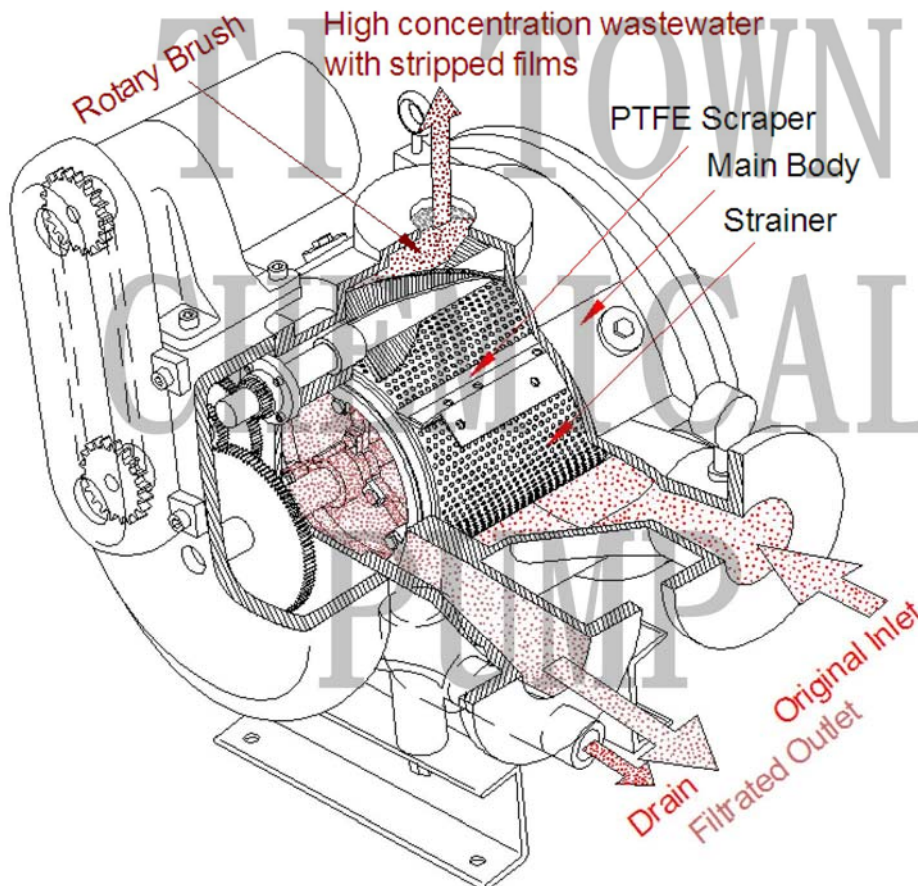

# Metal Bag Filter Housing

<b>FBL</b>	<b>A</b>	<b>1</b>	<b>V</b>	<b>40</b>	<b>F</b>
<b>Model (Max. pressure)</b>	<b>MATERIAL</b>	<b>Filter Bag SPEC.</b>	<b>Lid Oring</b>	<b>In/Outlet</b>	<b>Fitting SPEC.</b>
FBL : Inlet in the side of the Barrel with clamp fasten (5kg/cm <sup>2</sup> )	A : SUS316 B : SUS304	NO 1~4	V : FKM (Viton) E : EPDM T : Teflon encapsulated FKM	16A~80A	F : Flange (JIS 10kg/cm <sup>2</sup> ) MS : Male screw FS : Female screw
FBH : Inlet in the side of the barrel with eye bolt fasten (10kg/cm <sup>2</sup> ) *1					
FBU : Inlet in the Upper Lid with eye bolt fasten (10kg/cm <sup>2</sup> )					

■ Top open lid, easy cleaning the filter housing without any extra tools.

■ Filter Bag specification :

- NO.1 : Ø7" × 16"L
- NO.2 : Ø7" × 32"L
- NO.3 : Ø4" × 9"L
- NO.4 : Ø4" × 15"L

■ Filter Bag basket is made with perforated Ø 4.0mm  
Optional spot with fine wire netting  
( recommend 10~200 mesh)

■ Operating pressure

FBL : Lid fasten with clamp, design pressure is 7 kg/cm<sup>2</sup>, operating pressure is 5kg/cm<sup>2</sup> (Max.)  
FBH/FBU : Lid fasten with eye bolts, design pressure is 15kg/cm<sup>2</sup>, operating pressure is 10kg/cm<sup>2</sup> (Max.)

■ Surface treatment : Electro polishing

■ Specifications

Model	Filter bag SPEC.	Barrel Diameter (mm)	STD. Flow rate (M <sup>3</sup> /H) *2
FBL	1	Ø230	20
	2	Ø230	40
	3	Ø180	6
	4	Ø180	12
FBH	1	Ø216	20
	2	Ø216	40
	3	Ø140	6
	4	Ø140	12
FBU	1	Ø216	20
	2	Ø216	40

\*1 : FBH series biggest executable Multi-Bag Filter Housing is 12 pieces of BAG NO.2.  
The Barrel size is Ø965mm. STD. Flow rate 540 M<sup>3</sup>/H.

\*2 : STD. Flow rate is a reference value.  
Actually value is depends on filter SPEC. fineness & water turbidity.



# Metal cartridge Filter Housing

CFL	A	07	20	E	40	F
Model (Max. pressure) CFL (5kg/cm <sup>2</sup> ) CFH (10kg/cm <sup>2</sup> )	MATERIAL A : SUS316 B : SUS304	Number of cartridges 1~173	cartridge length 10"/20"/30"/40"	Lid Oring E : EPDM V : FKM (Viton) T : Teflon encapsulated FKM	In/Outlet 16A~300A	Fitting SPEC. F: Flang (JIS 10kg/cm <sup>2</sup> ) MS: Male screw FS: Female screw

■ Top open lid, easy cleaning the filter housing without any extra tools.

■ Operating pressure :

CFL : Lid fasten with clamp. Design pressure is 7kg/cm<sup>2</sup>. Operating pressure is 5kg/cm<sup>2</sup> (max.). Executable from 1~7 cartridges.

CFH : Lid fasten with eye bolts. Design pressure is 15kg/cm<sup>2</sup>. Operating pressure is 10kg/cm<sup>2</sup> (max.). Executable from 1~173. cartridges.

■ cartridge specification

ID : Ø28mm (Min.)  
OD : Ø70mm (Max.)

■ Surface treatment

- ① For Barrel diameter Ø600mm and below: electro polishing
- ② For Barrel diameter Ø650mm and above: pickling

## ■ Specifications

Number of cartridges	Barrel Diameter (mm)	STD. In/Outlet	STD. Flow rate (M <sup>3</sup> /H) * 1
1	Ø106	16A~25A	1~3
3~4	Ø181	20A~40A	3~9
5~7	Ø230	25A~80A	5~20
8~12	Ø300	50A~100A	24~48
13~20	Ø406	50A~100A	39~80
21~28	Ø486	50A~100A	63~112
29~36	Ø560	100A~150A	87~144
37~46	Ø600	100A~150A	111~184
47~56	Ø650	100A~150A	141~224
57~81	Ø762	100A~150A	171~324
82~95	Ø900	150A~200A	246~380
96~135	Ø1000	200A~250A	288~540
136~155	Ø1100	250A~300A	408~620
156~173	Ø1200	300A~350A	468~692

\* 1 : STD. Flow rate is a reference value.

Actually value is depends on filter SPEC. fineness & water turbidity.



CFL series

single cartridge housing



CFH series

single cartridge housing



CFL series

3~7 cartridges housing



CFH series

3~7 cartridges housing ( 8 cartridges and above )



CFH series

Multi-cartridge housing



## 鈦城科技有限公司

TI TOWN TECHNOLOGY CO., LTD  
桃園市龜山區忠義路二段332號  
Web site : [www.titown.net](http://www.titown.net)  
E-MAIL : [titown.pump@msa.hinet.net](mailto:titown.pump@msa.hinet.net)  
[service@titown.net](mailto:service@titown.net)

